

HT 380 Skid Steer Loader User Manual



Read Carefully Before Use
Keep for Future Reference

Contents

Preface	1
Reference Information	2
General Information	3
Symbol Guide	4
Safety Information	5
Operation Temperature Safety	5
Personal Safety	5
Operation Safety.....	6
General Operation Safety	6
Driving Safety	6
Load & Unload Safety	7
Worksite Safety	7
Oil Safety	8
Battery Safety	9
Maintenance Safety.....	9
Specifications	11
Loader Diagram	12
Assembling & Disassembling	13
Regular Work Equipment	13
Hydraulic Work Equipment.....	13
Operation	14
Pre-Driving Check	14
Balance & Protection.....	14
Control Panel.....	15
Starting the Engine	16
Driving	16
Left Control Rod.....	17
Right Control Rod	18
Changing the Speed.....	19
Honking	19
Head Light.....	19
Operation Timing & Maintenance Tracking.....	19
Attachment Control Rod.....	19
Emergency Shutdown.....	19
Transportation	20
Maintenance	21
General Maintenance	21
Periodical Maintenance	22
Lubrication.....	23
Engine.....	23
10-Hour Check.....	23
50-Hour Check.....	24
100-Hour Check.....	26
250-Hour Check.....	26
500-Hour Check.....	26
Jump Start	27
Contact Us	28

Preface

Congratulations on your new skid steer loader!

Welcome to the user manual for your skid steer loader. We are thrilled to provide you with a comprehensive guidance on operating and maintaining this powerful and versatile machine. Whether you're a seasoned professional or a newcomer to the world of heavy machinery, this manual is designed to be your reliable companion throughout your journey with the machine.

Within these pages, you'll find detailed instructions, safety guidelines, and valuable tips to ensure that you operate the skid steer loader efficiently, effectively, and most importantly, safely. Our aim is to empower you with the knowledge and confidence needed to harness the full potential of this equipment while prioritizing the well-being of both yourself and those around you. From assembling and starting up the skid steer loader to executing complex tasks, we've covered every aspect to make your experience seamless. Additionally, you'll discover insights into routine maintenance procedures that will keep your skid steer loader in prime condition, prolonging its lifespan and optimizing its performance.

Safety is paramount, and we emphasize the importance of adhering to the provided guidelines. This manual includes clear explanations of safety protocols, operational best practices, and hazard mitigation techniques. By prioritizing safety, you're not only protecting yourself but also creating a secure environment for your team and job site.

Remember, this manual is not just a technical document; it's a guide tailored to your needs. We encourage you to familiarize yourself with its content, explore its sections, and refer back to it whenever needed. Our commitment is to empower you with the knowledge necessary to make the most of your skid steer loader, elevating your capabilities and contributing to successful projects.

Thank you for choosing skid steer loader. Your journey starts here, and we're excited to embark on it together. Let's get started!

Reference Information

Write the correct information for your loader. Always use this information when referring to your loader.

Loader Serial No.	
Engine Serial No.	
Manufacture Date	
Manufacturer Address	
Dealer's Address	
Dealer's Contact Info.	



General Information

This skid steer loader is a highly maneuverable and compact machine. In operation, it is rugged and useful under a wide variety of conditions, which more often than not present operators with hazards associated with off-highway, rough terrain use scenarios. This machine has an internal combustion engine with resultant heat and exhaust, which can be fatal and inductive to diseases. Make sure the worksite is well-ventilated at all times.

Ensure that the worksite is well-ventilated at all times when operating the skid steer loader. Adequate ventilation helps dissipate exhaust fumes and heat, reducing the risk of exposure to harmful emissions.

This machine consumes gasoline. Handle gasoline safely. Store gasoline in approved containers, away from ignition sources, and follow all safety regulations and guidelines when refueling.

Only allow operators who are trained and qualified to operate the skid steer loader. Adequate training ensures that the equipment is used safely and efficiently.

Regularly inspect and maintain the skid steer loader according to the manufacturer's recommendations. This includes checking the engine, exhaust system, and ventilation components to ensure they are in proper working order.

ALWAYS wear appropriate personal protective equipment (PPE), including safety glasses, hearing protection, and other gear as necessary to protect against hazards. Steel-toe and anti-puncture footwear is highly recommended.

This machine has labels. Maintain them. If any lost, contact the customer service to get replacements.

Read these instructions carefully **PRIOR** to operating. **ALWAYS** check the national and local rule concerning the use of construction machinery.

Some utility lines may not be clearly signed. **ALWAYS** check before running the machine for digging.

When giving or being given training on the operation, make sure the training consists of demonstration as well as verbal instruction. Rookie driver **MUST** take his test drive in a location without bystanders

ALWAYS know the nature or property of the material you are handling using the skid steer loader. For instance, asbestos poses fatal threats if inhaled. Logs can tumble to crush if not stacked in the correct way. Use your discretion and **ALWAYS** know what you are going to handle beforehand.

NEVER operate under the influence of alcohol, drugs, or heavy medications. **DO NOT** push your limit. Rest as needed. Do not grant use to any persons who physical capability and mental status preclude safe operation of the machine.

DO NOT force the skid steer loader. Limit the load of the bucket any other work equipment south of 826 lb. (375 kg).

Symbol Guide

This section lists symbols that may be included in this manual or found attached to your skid steer loader. Familiarize yourself with you.



These items present a risk of death



These items present a risk of serious property damage or personal injury



These items present a risk of fire or explosion.



These items present a risk of electric shock.



These items present a risk of skin-burns.



Wear personal protective equipment.

Safety Information

Operation Temperature Safety

Warning!

- For proper functioning and expected performance of your machine, **DO NOT** operate if the ambient temperature is higher than 113°F (45°C) or lower than 5°F (-15°C).
Being operated under an ambient temperature higher than 113 °F (45°C) can cause the engine to overheat, compromise your energy efficiency, shorten the service life of the hydraulic system
- If the skid steer loader works under an ambient temperature below 5°F (-15°C), the gaskets and other rubber parts may be frozen hardened, causing early and excessive wear.
- Under cold temperatures, the engine may take some time to warm up before working normally. After starting up, let it run idle for a couple of minutes and allow all systems a few minutes to get ready.

Personal Safety

Warning!

- **DO NOT** wear loose clothes or accessories that may get caught into the moving parts of your skid steer loader in operation. Wear clothes that are oil-repellent. Replace them if grim or grease has started to build up. Fabrics coated or soaked with grim can burn in proximity to heated machinery.
- **ALWAYS** use personal protective equipment (PPE) suitable to your task. Always wear ANSI and OSHA-approved eye, breathing, and hand protection while using this product. Nonslip and steel-toe footwears are also highly recommended. Other equipment such as ear, head, and body protection may also be necessary depending on your work, work environment, and other equipment.

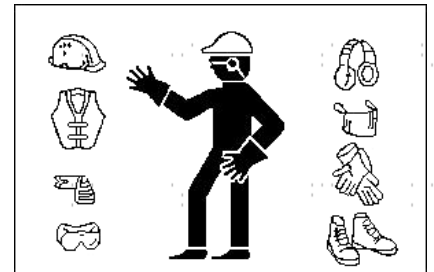

- **ALWAYS** keep a fire extinguisher and first-aid kit at an easily accessible place. Familiarize yourself with the protocols for using the first-aid kit and operating the fire extinguisher. Ensure that you provide training to other individuals who will be operating the skid steer loader. This ensures that everyone is prepared to handle potential emergencies effectively.

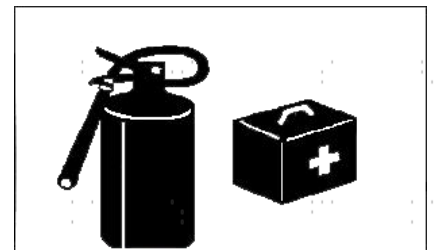

- Display the contact details of the nearest Emergency Room (ER) prominently in the operator's area. Make sure that all personnel operating the skid steer loader are well-informed about this information.

Operation Safety

Warning!

General Operation Safety

- Due to the nature of construction work, the use of a signalman or flagman is necessary. Always make sure that you fully understand the gestures and signals used by your signalman or flagman and so do all the persons involved in the work. If at any time such a way of communication fails, use an intercom communication.
- Prior to commencing any operations, run a comprehensive drill rehearsal to ensure that every participant comprehends, can effectively respond to, and proficiently practice both the designated signals and emergency protocols.
- Clean the soles of your shoes of any dirt, grease, or gravel before going onto the operation platform. Greasy or grimy outsoles **WILL** compromise your balance.
- **ALWAYS** lower your work equipment to the ground and shut the engine down before leaving the operation platform. Store the key(s) in a designated place inaccessible to unauthorized use.
- **DO NOT** operate on soft or damp soil ground, on which this skid steer loader may lose equilibrium and fall over. **DO NOT** operate on unstable ground. If the ground vibrates or shakes as your drive over, cease driving and abort the skid steer loader immediately.
- **NEVER** operate from a location other than the operation platform.

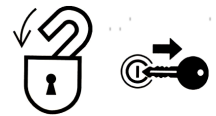
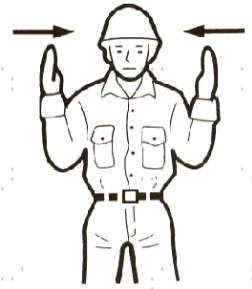

Driving Safety

- **ALWAYS** check with the signalman or flag man that there is no person standing within the operating radius of the skid steer loader.



- Maintain a low speed while traversing rough terrain; avoid abrupt starts, stops, or sudden changes in direction. Such actions could lead the working device to come into contact with the ground, jeopardizing the skid steer loader's as well as your balance.
- Exercise caution when navigating slopes. Refrain from operating on excessively steep slopes (no greater than 30°) where the skid steer loader's stability is compromised. **NEVER** make sharp turns whether going uphill or downhills.
- Exercise **EXTREME** caution when operating on snow or ice. Objects situated on the road shoulder or roadside may be concealed beneath the snow, rendering them invisible. This poses a risk of overturning or colliding with these snow-covered objects. Therefore, exercise caution while operating the skid steer loader in such conditions. Consult professional advice before attempting to operate under extreme weather conditions.

- **DO NOT** drive on newly paved asphalt roads or other similarly heated surfaces, as this **WILL** compromise the service life of the tires.
- When operating on a slope, it is important to keep the attachment or load low. Additionally, you should drive slowly and exercise caution at all times. This is essential for maintaining stability and preventing accidents when working on inclined terrain.
- When moving up and down slopes, ensure that the heavy end of the unit is positioned uphill. The distribution of weight may vary depending on the attachments and load being carried. For instance, an empty bucket can make the rear of the unit heavier, while a full bucket can shift the weight to the front. Most attachments tend to make the front of the loader the heavy end.
- Avoid starting, stopping, or making sharp turns when operating on slopes. If it's necessary to make a turn, do so while keeping the heavy end of the unit uphill. This precaution helps maintain stability and minimizes the risk of rollovers.
- **DO NOT** park the loader on a slope without taking specific safety measures. Ensure that the work equipment is lowered to the ground, return all controls to the neutral position, turn the ignition switch to its off position, and reinstate all control rods. Choke the wheels after parking the loader on a slope.

Load & Unload Safety

- **NEVER** raise the bucket over any persons, not even a driver sitting in the cockpit.
- **ALWAYS** ensure the driver's safety when loading. Do not apply load until the driver arrives at a safe place. **ONLY** load/unload from the back of a vehicle.

Worksite Safety

DANGER!

- **ALWAYS** free your worksite of any sparks or flame. The fuel, lubricating oil, grease, and anti-freeze inside the skid steer loader are flammable. Keep the welding and soldering devices away from the skid steer loader.
- **ALWAYS** forbid smoking at and around your worksite. Keep the appropriate type of extinguishers (usually Class B extinguishers for gasoline fires) nearby. Get trained or train the personnel involved on the use.
- **NEVER** use your cellphone or any other similar device when filling the fuel or lubricating oil.
- Keep your worksite well-lit at all times. Use additional illumination when necessary. **DO NOT** operate if you don't have a clear vision.
- Keep your worksite well-ventilated. **NEVER** operate in a closed area with poor ventilation. If you must and natural ventilation is impossible, install a ventilation fan and lengthen the exhaust pipe to make sure the fume doesn't get denser inside the closed worksite.
- Some construction materials may contain asbestos. Exercise **EXTREME** care and discretion when dealing with the material. Make sure all the personnel involved wear either a half-face or full-face respirator paired with a NIOSH-rated N100, R100, or the more common P100 filter. Do not use compressed air to clean your worksite.

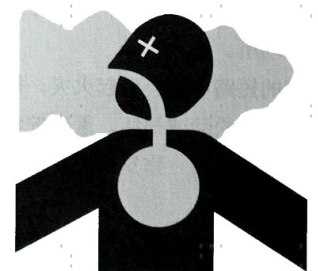

DO NOT polish or grind materials containing asbestos. If working indoors and there is asbestos dust, require all the personnel involved to wear the respirator mentioned above and install a ventilation system with polymer filter before actually working on material containing asbestos. Limit access to the worksite to authorized personnel and follow the national and local codes and regulations concerning the disposal and handling of asbestos.

- **DO NOT** put any part of your body into any moving parts of the skid steer loader. The clearance may change when it moves. Train the ground personnel about this, evacuate your worksite of any bystanders, and enclose your worksite with barriers or hurdles before operation.
- **ALWAYS** inspect the terrain and the ground in the worksite before operation. Inspect the building structure for indoor operation, being sure the structure can bear the operating mass of the skid steer loader. When walking on a structure like a bridge, make sure the structure can bear the operating mass of the skid steer loader.
- **ALWAYS** know the locations of obstacles such as ditches, utility lines such as gas, power, water lines, and things that might fall such as trees, overhead wires or stones on a cliff.

Oil Safety



- **DO NOT** remove the fuel tank cap or fill the fuel while the engine is running or still hot. When filling oil, watch out not to splash the oil onto the skid steer loader's hot surfaces or electronic components.
- Forbid smoking in the worksite.
- **IMMEDIATELY** clean the fuel or lubricating oil overflows.
- **ALWAYS** wait till the engine has cooled before refueling. **ALWAYS** fill the fuel tank in a well-ventilated location. Refuel carefully and clean overflows or splashed **IMMEDIATELY**.
- Avoid filling the fuel tank to its maximum capacity; leave room for oil expansion. Immediately address any fuel spillage. Ensure the fuel tank is securely fastened. If the tank cover is absent, replace it with an identical one. Refrain from using unauthorized tank covers that lack proper ventilation, as they could lead to internal pressure buildup.
- Choose gasoline with an octane rating of 90 or higher. In cold climates or at high altitudes, consider using gasoline with a higher-octane rating.
- Ensure that the gasoline you use has a sulfur content below 0.05–0.0015%. In the United States or Canada, opt for gasoline with ultra-low sulfur content. Using gasoline with high sulfur levels can lead to corrosive damage to the engine cylinders.
- Avoid the use of kerosene. Refrain from mixing kerosene, used lubricating oil, residual fuel, or other additives with diesel oil. Poor-quality fuel can undermine engine performance or cause damage.
- It is not recommended to use fuel additives, as some additives may degrade engine performance. Additionally, metals like zinc, sodium, magnesium, silicon, and aluminum should be limited to one part per million (1 ppm mass) or less.
- Dispose of the cloths or any similar cleaning towels soaked or saturated with the engine oil, hydraulic oil or lubrication grease following all the national, local codes and regulations regarding the disposal of such wastes. Use a separate container for such oily wastes.

Battery Safety



- **ALWAYS** wear personal protective gears when handling the battery. Gloves and goggles are necessary.
- **ONLY** use batteries of the same voltage as the one that came with the loader.
- When jump starting, follow the instructions on connecting the terminals and the cables.
- Dispose of old or used batteries following local, state, and federal regulations regarding battery disposal. Most lead-acid batteries are recyclable, and many recycling centers accept them.
- When working in an enclosed space or area with poor ventilation, be cautious of battery fumes and gases. Lead-acid batteries, in particular, can release hydrogen gas during charging or discharging, which can be flammable and harmful if inhaled. Ensure that you are working in a well-ventilated area to disperse any fumes.

Maintenance Safety

- **ONLY** have this skid steer loader maintained and serviced by a certified mechanist following the specific maintenance cycles stated in this manual.
- **ONLY** replace damaged parts with identical ones. If such parts can't be procured locally, contact the Customer Service.
- **DO NOT** modify the skid steer loader. Unauthorized retrofitting of the skid steer loader may cause injury or even death, for which the manufacturer and importer of the skid steer loader will not be held liable.
- **ALWAYS** check that the labels and signages are legible. If damaged, replace them with identical ones.
- **ALWAYS** keep the skid steer loader clean, especially parts that the driver steps on or holds on to. Wipe grim, grease, dirt, snow or ice off of them to prevent accidental falling.

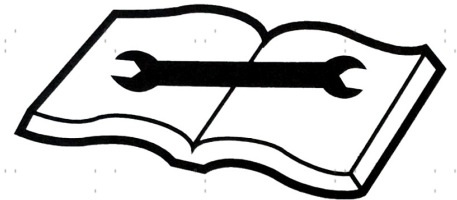

- **ALWAYS** check the inlets and outlets of the engine for any obstructions.
- **ALWAYS** mark the skid steer loader with a “**DO NOT OPERATE**” sign if any malfunction arises. Hang the sign on a prominent location, preferably on any of the control rods.



- When handling heavy objects or accessories during removal or installation, ensure they are placed in a secure and stable location. Restrict unauthorized individuals from accessing the area where such items are stored.



- **ONLY** use explosion-proof lamps when examining fuel, lubricating oil, coolant, or battery electrolyte. Failure to do so could lead to severe injuries or fatalities caused by an explosion.



- **NEVER** use damaged tools or tools with poor performance or tools with other purposes to service this excavator.



Specifications

Engine	Model	BRIGGS & STRATTON 3864	
	Rated Power	23 hp	
	Rated Speed	3600 rpm	
	Rated Torque	35 ft lb. / 47.5 Nm @ 3060 rpm	
	Replacement	38.3 in ³	627 cm ³
	Oil Volume	57.5 fl oz	1.7 L
	Type	10W-30	
Fuel System	Tank Volume	5.28 gal.	20 L
	Type	#90 or over	
Hydraulic System	Pumps Pressure	2320.6 psi	16 MPa
	Oil	SAE 20W	#46
	Oil Flow (ea.)	6.07 gal/min	23 L/min
	Tank Volume	6.6 gal.	25 L
Battery	Type	Lead-Acid	
	Capacity	45 Ahr	
	Terminals	18 & 17 mm Posts	
	Voltage	11.2 V	
	CCA	405	
Bucket	Width	45.3 in.	1150 mm
	Volume	5.3 ft ³	0.15 m ³
	Swing Angle	55°	
	Dump Angle	32°	
Performance	Max. Speed	3.17 mph	6 kph
	Max Capacity	440 lb.	200 kg
	Max. Lifting	826 lb.	375 kg
	Max Slope Grade	30°	
	Max. Unloading Height	57.6 in.	1465 mm
	Max. Chassis Clearance	4.6 in.	118 mm
Dimensions (with Bucket)		82.1×45.3×51.7 in.	2085×1150×1312 mm
Max Noise Level		95 dB	
Weight		1733 lb.	786 kg
Compatible Work Equipment		Auger, Rock Bucket, Bucket, Hydraulic Breaker, Dozer Blade, Soil Ripper, Mixing Bucket, Stump Grinder, Grading Blade, 4-in-1 Bucket, Log Splitter, Plate Compactor, Log Grapple, Forklift, High-Dump Bucket, Lifting Device, & Lawn Aerator	
Incompatible Work Equipment		Rotary Tiller, Lawn Mower, Snow Blower, Enclosed Sweeper, Trencher, Sweeper, & Ditch Filler	

Loader Diagram

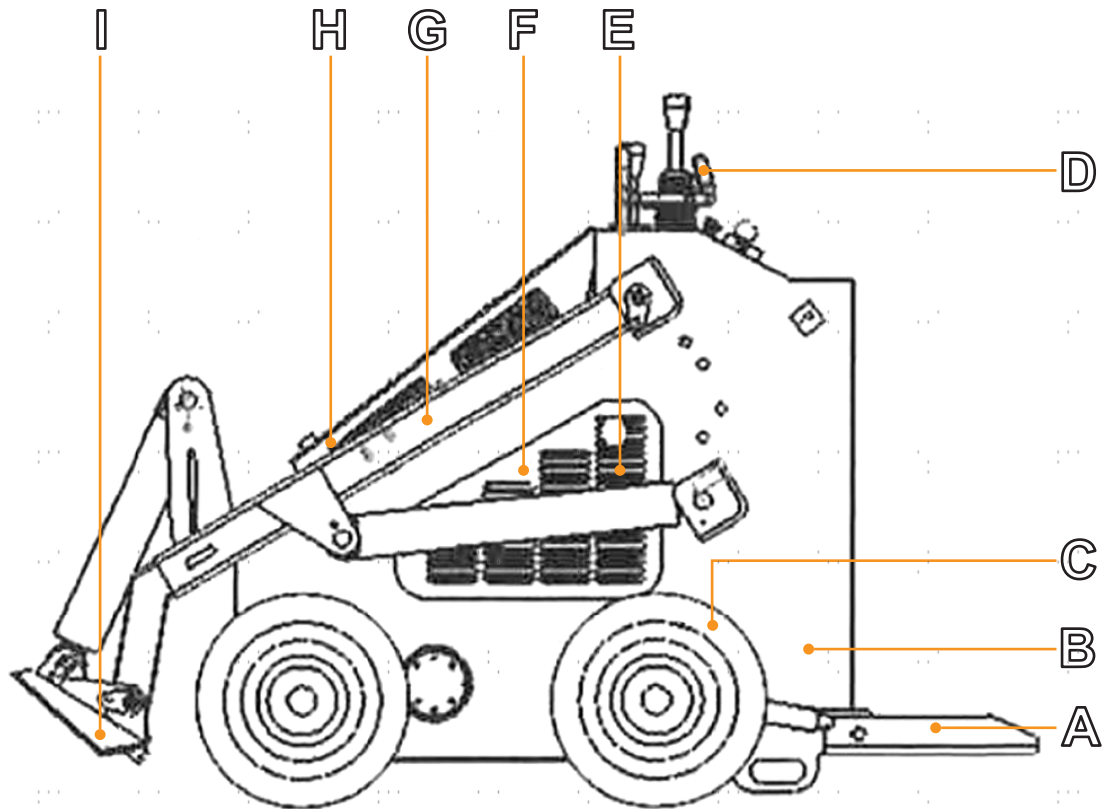

No.	Item
A	Operator Platform
B	Main Body
C	Tire

No.	Item
D	Control Panel
E	Engine (Not Shown)
F	Side Cover

No.	Item
G	Lift Arms
H	Upper Cover
I	Mount Plate

Assembling & Disassembling

Regular Work Equipment

 **ONLY** use compatible attachments as listed in **Specification**. **ALWAYS** consult professional advice before using a work equipment different than what you had been trained to operate.

 Before connecting a new attachment, ensure that the mount and receiver plates are free of dirt and debris.

1. Start the engine following the normal protocols as specified in **Starting the Engine** and push the right control rod left so that the work equipment is not tilted.
2. Push the left control rod left to lay the work equipment on the ground.
3. Shut the engine.
4. Pull the lock pin handles as shown on the mount plate away from the center of the attachment.
5. Remove the freed attachment using at least two people.
6. Refer to the manual of the attachment to be install to fix it to the mount plate. If unsure at any point, consult a mechanist.

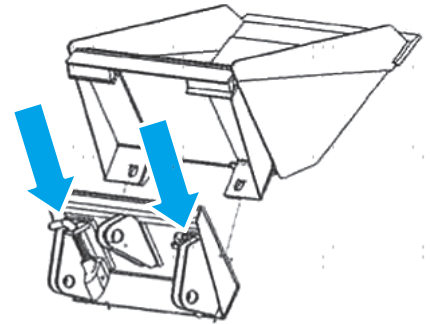



Hydraulic Work Equipment

 **WARNING!** Wear gloves and other protective gear and use **EXTREME** care when handling the hydraulic hoses, which may remain hot enough to cause skin-burns.

 **WARNING! ALWAYS** set the attachment control rod neutral before handling the hoses.

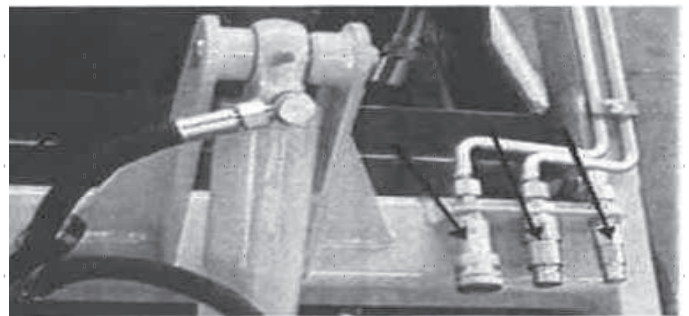
1. Follow the steps above to remove the work equipment, whose working requires no hydraulic power. Shut the engine.
2. Follow the manual of the work equipment, whose working requires hydraulic power, to attach it to the mount plate.
3. Push and pull all the control rods several times so that there is no residual pressure at the hydraulic couplers.
4. Ensure that all controls are in neutral position.
5. Remove dirt and debris from the hydraulic couplers.
6. Connect the male coupler on the equipment (not included) to the female coupler on the loader.
7. Connect the female coupler on the equipment to the male coupler on the loader.
8. Connect the female coupler on the case drain hose to the case drain coupler on the loader, if any.



 If the couplers on your equipment do not fit the couplers on the loader's hoses, use the provided adaptors.

9. Reset the lockpins to secure the work equipment.

Operation



Your loader **MUST** work under 80% of its full capacity for the first hundred hours before it is allowed to unleash its maximum capacity. Refer to the table for the recommended capacity at different stages. Use the hour meter to time your operation and track your operation schedule.

Hours	Capacity
≤ 10 hours	≤ 60%
≤100 hours	≤ 80%
Over 100 hours	100%



WARNING! Forcing the loader .in its first hundred hours **WILL** increase wear and substantially shorten its service life.



Pre-Driving Check



CAUTION! ALWAYS run the following checks before starting the loader.

- Check that you have carefully read this manual and undergone a proper training.
- Check that you have donned personal protective equipment necessary for the task.
- Check that all buttons, switches, and control rods are off or at neutral positions.
- Check that this is no grime or grease that may compromise your balance on the operation platform.
- Check that the engine oil, hydraulic oil, and fuel meet the operating requirements.
- Check that the hydraulic system is free of any damage or leakage. Repair before operating.
- Check that your signalmen are in position and there are no other bystanders in the worksite.

Balance & Protection



DANGER! Since the loader has no driver's seat or cab. You must exercise **EXTREME** care when maneuvering this loader. In case of sudden and violent bumps, use your judgment and discretion to decide whether you hold on to the loader's handle or abort it. You **MUST** wear a helmet and other personal protection equipment.

Control Panel

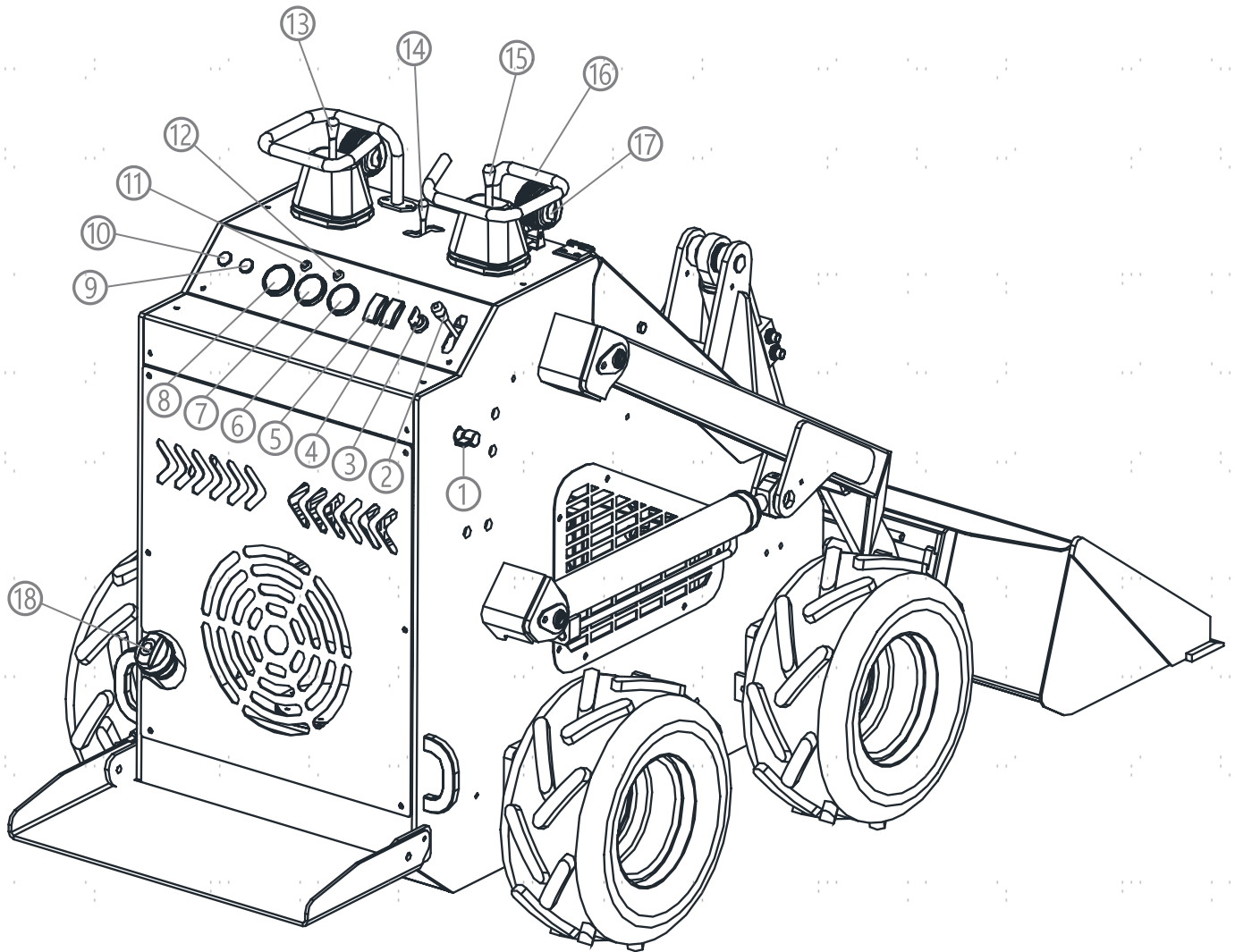

No.	Item
①	Power Switch
②	Throttle Handle
③	Engine Start
④	Horn
⑤	Headlight Switch
⑥	Hour Meter
⑦	Fuel Gauge
⑧	Oil Temperature
⑨	Engine Choke

No.	Item
⑩	12–24V Outlet
⑪	Oil Cooler indicator
⑫	Electric Indicator
⑬	Left Control Rod
⑭	Attachment Control Rod
⑮	Right Control Rod
⑯	Handle
⑰	Headlight
⑱	Fuel Filler

Starting the Engine

1. Check that the worksite is free of bystanders.
2. Check that the control rods, including the attachment control rod, are at their neutral positions. If not, make them so.
3. Locate the power switch, which should be on the right side of the control panel. Turn it to its **ON** position.
4. Insert the ignition key and turn it to its **ON** position.



 If you are operating at a high altitude or the specific conditions make it hard for the engine to start, pull the knob marked **CHOKE** a little bit to facilitate the ignition. Remember to replace it when the engine has started.



5. The engine should be up and running. Do not operate yet. Allow it to run idle for a minute or so.

 For a longer battery life. Cut the power when the ignition key is turned to its **OFF** position.

Driving

The two control rods control the moving and steering of the loader.

To drive forward, follow the steps as mentioned above to start the engine. Push them simultaneously forward and hold them there to move the loader forward. Once released, the loader will stop immediately.

To drive backward, follow the steps as mentioned above to start the engine or stop the loader by reinstating the control rods. Pull the rods simultaneously to move the loader backward. Once released, the loader will stop immediately.

 **NEVER** pull or push the rod abruptly when the loader is mobile in either direction.

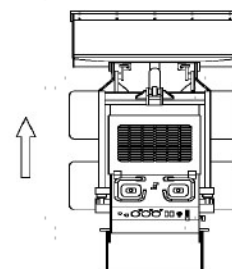
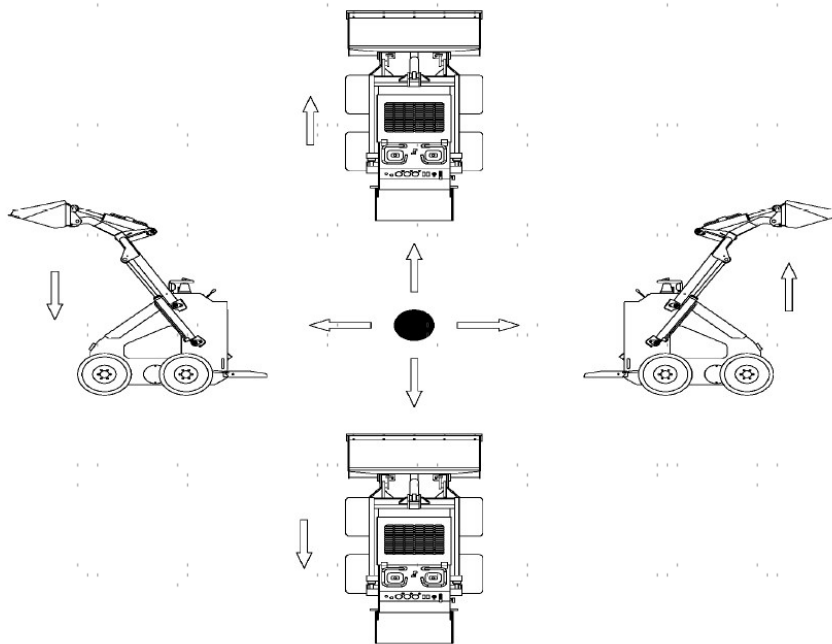

Left Control Rod



 Forward	Pushing the left control rod ⑬ away from you controls the left wheels to move forward. Pushing the rod away from you while the loader is mobile controls the loader to turn right.
---	--

WARNING! NEVER push or pull any rod abruptly while mobile as this **WILL** cause the loader to suddenly move and cause you to fall off the operation platform.

DANGER! NEVER make sharp turns or starts when the loader is heavily loaded.

 Backward	Pushing the rod toward you controls the left wheels to move backward. Pushing the rod away from you while the loader is mobile controls the loader to turn left.
 Right	Pushing the rod to the right raises the lift arms.
 Left	Pushing the rod to the left lowers the lift arms.

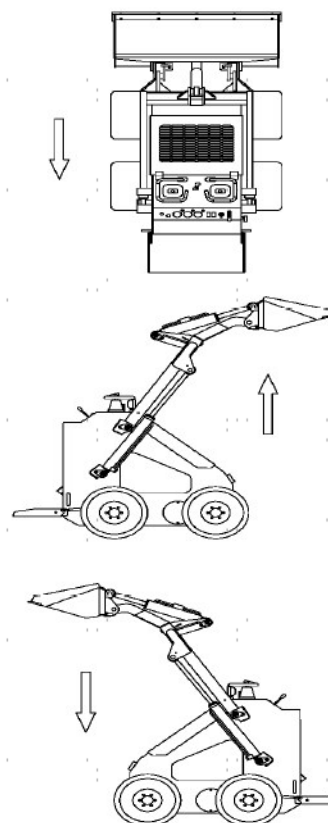

WARNING! DO NOT overload the bucket as this **WILL** damage the arm cylinders or even topple the loader.

Right Control Rod

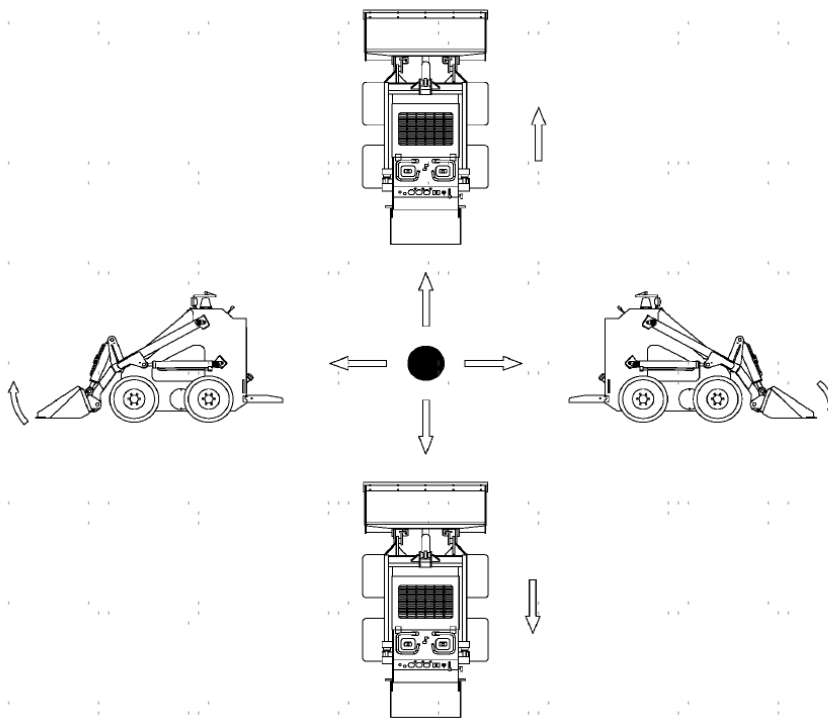

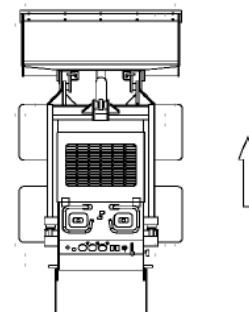

 Forward	Pushing the left control rod ⑮ away from you controls the right wheels to move forward. Pushing the rod away from you while the loader is mobile controls the loader to turn left.
---	--



WARNING! NEVER push or pull any rod abruptly while mobile as this **WILL** cause the loader to move suddenly and cause you to fall off the operation platform.

DANGER! NEVER make sharp turns or starts when the loader is heavily loaded.

 Backward	Pushing the rod toward you controls the right wheels to move backward. Pushing the rod away from you while the loader is mobile controls the loader to turn right.
 Left	Pushing the rod to the left raises bucket.
 Right	Pushing the rod to the right makes the bucket dump.

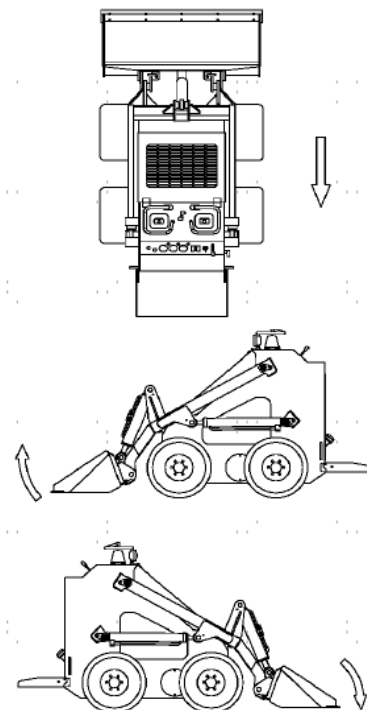

WARNING! DO NOT overload the bucket as this **WILL** damage the arm cylinders or even topple the loader.

Changing the Speed

The throttle handle ②, marked with a rabbit and turtle, controls the speed. Pulling it towards you speeds up the loader while pushing it away from you slows the loader down.



Honking

The horn will keep sounding if the horn's switch ④ is not toggled back. Remember to reinstate it when honking is not needed.

Head Light

Toggle the switch ⑤ to use the headlight. Remember to reinstate it when it is not needed, especially when the engine is idling.

Operation Timing & Maintenance Tracking

Use the hour meter ⑥ to time and track your operation and maintenance schedule.



Attachment Control Rod

Forward: Pushing the rod ⑭ away from you (forward) extends the hydraulic attachment installed.

Backward: Pull the handle toward you (backward) resets the hydraulic attachment.

Neutral: When the rod is in neutral, the hydraulic pressure is relieved.



WARNING! NEVER attach or remove any hydraulic attachments unless the attachment control rod has been set in neutral. Failure to do so can result in serious injury due to the pressurized, high-temperature hydraulic oil.



Emergency Shutdown

Turn the ignition key to its off position and turn the power switch to its off position.

Transportation

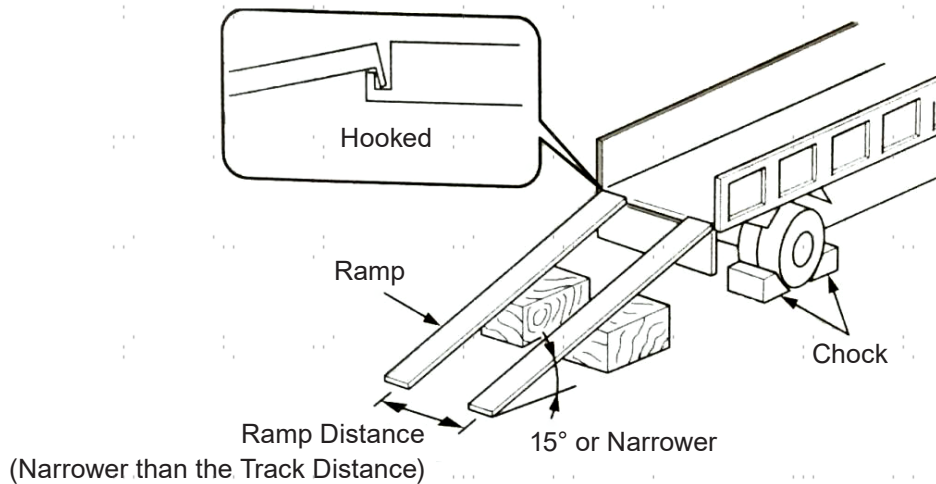
1. Select a sturdy, level ground area at a safe distance from the roadside.
2. Securely fasten two ramps with adequate strength and dimensions to the truck bed. The incline angle must not exceed 15°. If the ramp is too steep, utilize a support pillar or block underneath them. Make certain that the ramps are wide enough for full contact with the wheels of the loader. Refer to the picture for the truck and ramp preparation.



-  Do not use the work equipment for loading or unloading the loader, as this could result in rolling or falling.
-  Ensure the truck and loading surface are clean, devoid of oil, sand, ice, snow, or any foreign materials to prevent the loader from sliding. Clean the wheels.
3. Steer the loader to travel slowly onto the ramps, being sure the wheels are fully on the ramp.
 **Danger! DO NOT** change direction when on the ramps. Travel slowly and steadily.
4. Stop when the whole loader is inside the truck bed. Shut the engine, ensure all control rods are at neutral and remove the keys.
5. Use chocks to immobilize the loader's wheels. Secure the machine to the truck using a cable or chain if possible. Lock the trunk doors and lids if any.

Maintenance

General Maintenance

- Clean the control panel with a cloth wetted in mild detergent to wipe panel clean.
- Clean the platform of any grime, grease, or mud buildups. **NEVER** use kerosene as a cleaning detergent.
- Park the loader indoors or cover the control panel with water-proof canvas if is to be unused for a prolonged period of time, since the panel is not water proof.
- Periodically check the tire for any cracks. If damaged, replace with identical ones. Periodically check the pressure of the tire. Inflate them to the recommended pressure.
- Periodically check the inlets and outlets of the engine for any obstructions. If found, remove **IMMEDIATELY** before starting the engine.
- Run a pre-operation inspection before each use. Check for loose or damaged parts, leaks, worn-out components, and signs of wear and tear.
- Periodically check that all safety features, such as the headlights, horns and labels are functioning and legible.
- Check engine oil levels regularly and change the oil according to the engine's manual.
- Inspect air filters and replace them when they are dirty or clogged.
- Keep the cooling system clean and ensure the radiator is free of debris to prevent overheating.
- Periodically check the hydraulic hoses and connections for leaks, cracks, or damage. Check hydraulic fluid levels and top up as needed. Replace hydraulic filters per the instructions in Periodical Maintenance below. Monitor hydraulic fluid temperature to prevent overheating.
- Keep the fuel tank and fuel lines clean to prevent debris from entering the system.
- **ONLY** Use the recommended fuel to avoid engine issues.
- Periodically check the battery for corrosion and loose connections. Clean and tighten as necessary. Cut the power if the loader is not needed.
- Periodically test all lights, gauges, and electrical components to ensure they are functioning correctly.
- Lubricate all grease points, including pivot points and joints, per the instructions in Periodical Maintenance below. Regular greasing helps reduce wear and tear.
- Maintain a maintenance log to record inspections, repairs, and servicing.
- Provide proper training to operators and ensure they are familiar with safety protocols and maintenance procedures.
- Schedule routine professional servicing by a qualified technician or service center to perform more extensive maintenance tasks and inspections as recommended by the manual and the engine's manual.

Periodical Maintenance

Lubrication

Lubricate the joints listed below after 5–8 hours of consecutive use, using EP3 lithium grease lubricant.



WARNING! Incorrect procedures could result in death, injury, or property damage. Follow the instructions and consult a mechanist if unsure at any point.



DANGER! Unless otherwise instructed, all service should be performed with the engine off. Stop engine and apply parking brake before opening hood for inspection or service. Allow the engine run idle for some time before shutting it down.



Proper lubrication is key to a longer service life of parts that move around an axle or shaft. Service intervals listed are for minimum requirements. Under extreme conditions, service the loader more frequently. **ONLY** use the recommended lubricant.



DANGER! Support both lift arms before working under raised lift arms.

No.	Parts	Lubricating Interval
①	Lift Arm Cylinder Rear Joint	5–8 Hours
②	Lift Arm Joint	
③	Lift Arm Cylinder Front Joint	
④	Bucket Cylinder Joint	
⑤	Mount Plate Upper Joints	
⑥	Mount Plate Lower Joints	

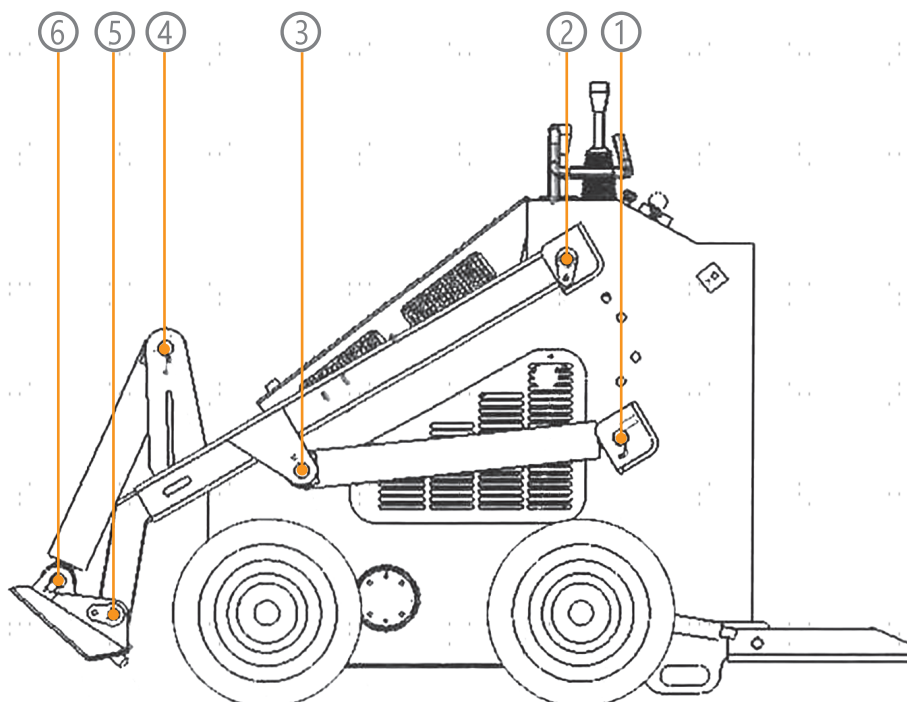

Engine

Refer to the engine's manual (included) for maintaining the engine.

 **WARNING! NEVER** maintain a running engine.

10-Hour Check

Hydraulic Oil Check

Every 10 hours of continual operation,

1. Locate the hydraulic oil cap as shown.
2. Remove the cap and pull out the oil dipstick.
3. Check that the oil mark is within the normal level, which is the section between the marks 1 and 2.
4. Refill with the recommended hydraulic oil if needed.

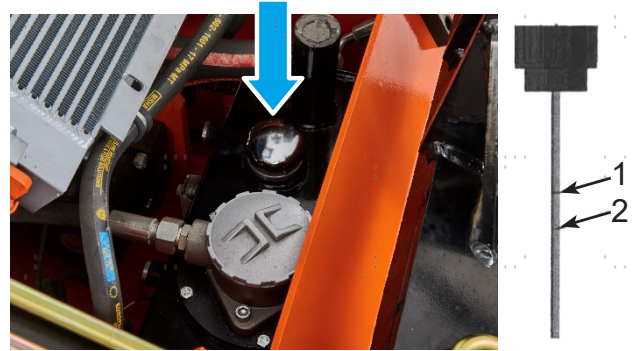

Hydraulic Hoses Leakage Check

Every 10 hours of continual operation, check all the hydraulic hoses for leakage. Normally, the parts of a hose as shown are more prone to damage.

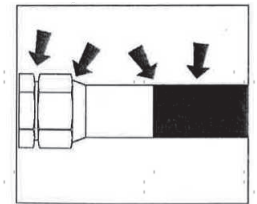

1. Shut the engine if it is running and allow it time to cool. Support the lift arms with sturdy buttresses. Hoist them if necessary

 **DANGER! ALWAYS** support both lift arms **BEFORE** working under the raised lift arms.

2. Toggle all the control rods to depressurize the hydraulic system.

 **WARNING! NEVER** service a pressurized hydraulic system

3. Put on necessary protective gears, including goggles and mask.

 **ALWAYS** wear protective gears before the check.



4. Replace damaged hoses or adaptors with identical ones.

 Drain the leaked hydraulic oil in an air-tight container and dispose of it following all national and local laws and codes.

 Seek immediate medical attention if your eyes have contacted the hydraulic oil.

50-Hour Check

Every 50 Hour of continual use,

No.	Task	Notes
1	Check the battery	
2	Check the drive belt	
3	Check the oil filter	
4	Clean the oil cooler	
5	Change the hydraulic oil filter	

Battery Check & Storage

Normally, regular battery can last 10–15 days in winter and 5–6 days in summer without any maintenance. After that, Follow the steps below to check it.



WARNING! ALWAYS wear protective gears before the check.



WARNING! Seek immediate medical attention if your skin has contacted the electrolyte.

1. Shut the engine if it is running.



WARNING! Never disconnect the battery when the engine is running.

2. disconnect the lines on the battery.



WARNING! ALWAYS remove the line on the negative post first and replace it last.

3. Remove the ventilation plug.
4. Check the electrolyte in each unit. Ad distilled water if the liquid level is below the lowest level allowed.
5. Reinstall the ventilation plug and the lines.

For maintenance-free battery, check the battery every 50 hours.

1. Shut the engine if it is running.



WARNING! Never disconnect the battery when the engine is running.

2. Remove the lines from the terminal posts.



WARNING! ALWAYS remove the line on the negative post first and replace it last.

3. Check that the posts are free of any grime or corrosion. Clean as needed.
4. Use a hydrometer (not included) to check the electrolyte following the manual of the hydrometer.



WARNING! Seek immediate medical attention if your skin has contacted the electrolyte.

5. Reinstall the lines.

If the loader is to be unused for a prolonged period of time, to protect the battery,

1. Disconnect the battery from the skid steer loader.



WARNING! ALWAYS remove the line on the negative post first and replace it last.



WARNING! When working in an enclosed space or area with poor ventilation, be cautious of battery fumes and gases. Lead-acid batteries, in particular, can release hydrogen gas during charging or discharging, which can be flammable and harmful if inhaled. Ensure that you are working in a well-ventilated area to disperse any fumes.

2. Use a battery charger to bring the battery to a full charge, following the charger's manual.
3. Clean the battery terminals to remove any corrosion or grime. Use a mixture of baking soda and water or a dedicated battery terminal cleaner to clean the terminals thoroughly.
4. Dry the terminals with a clean cloth.
5. Store the battery in a cool, dry location away from direct sunlight and inaccessible to children.
6. Periodically charge the battery during storage. Batteries tend to self-discharge over time, and keeping them charged helps prevent damage from complete discharge. Use a battery maintainer or trickle charger designed for long-term storage to maintain the battery's charge.
7. Keep the battery Clean. While in storage, periodically check the battery for any signs of corrosion or leaks. Clean the terminals if necessary and ensure the battery remains clean and dry.
8. Inspect before reuse. When you plan to use the skid steer loader again, inspect the battery. Recharge it if needed, and check for any visible damage or signs of deterioration. If the battery shows significant degradation or no longer holds a charge, replace it with an identical one.

• Oil Cooler Cleaning

Normally, the oil cooler needs to be cleaned every 50 hours of continual use. Shorten the cleaning schedule if the loader frequently operates under dusty conditions. Clean with compressed air or low-pressure water following the protocols for using such tools. Remember to wear personal protective equipment before cleaning.



CAUTION! Be careful with the fins on the cooler. They are sharp but can be easily warped. **DO NOT** clean them with hard objects.

• Changing the Hydraulic Oil Filter

Change the hydraulic oil filter after the first 50 hours of continual use. Then, change it every 250 hours.

100-Hour Check

- Engine Oil

Change the engine oil every 100 hours of continual use, referring to the engine's manual.

200-Hour Check

- Spark Plugs and Gaps

Check the spark plugs and gaps every 200 hours of continual use, referring to the engine's manual.

- Oil Filter Changing

Change the oil filter every 200 hours of continual use, referring to the engine's manual.

250-Hour Check

No.	Task	Notes
1	Change hydraulic oil filter	
2	Change air filter, check inner element	

Change the hydraulic oil filter every 250 hours of continual use.

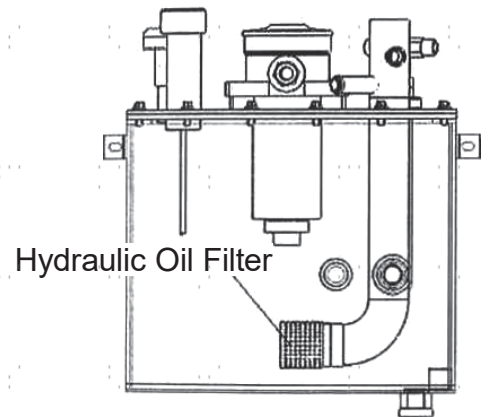

500-Hour Check

- Changing the Hydraulic Oil

Change the hydraulic oil every 500 hours of continual use.

1. Fetch a container for draining the used hydraulic oil and place it under the hydraulic oil drain port as shown.
2. Remove the drain cap.
3. Drain the oil and wait for remaining oil to sap and drip.
4. Replace drain cap, making sure it's securely locked in place.
5. Remove the hydraulic oil cap.
6. Fill the correct hydraulic oil while constantly check the oil level using the dipstick on the hydraulic oil cap.



CAUTION! ONLY use the recommended SAE 20W (#46) hydraulic oil.

Hydraulic Oil Cap

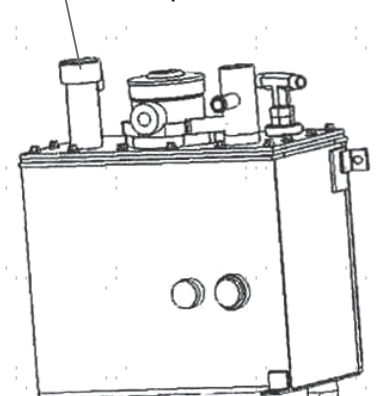

Hydraulic Oil Drain Port

Jump Start

Tools Needed but Not Included

No.	Tools
1	Vehicle with a Compatible Voltage System
2	Jumper Cables
3	Safety Goggles and Gloves

 **WARNING! ALWAYS** check that the assisting vehicle you are going to use has a compatible voltage system with the loader's battery.

 **WARNING! ONLY** use jumper cables capable of handling the jumping voltage.

1. Ensure that both the skid steer loader and the assisting vehicle are in a safe location, ideally on a level surface away from traffic and obstacles.
2. Turn off the ignition on both vehicles.
3. Identify and locate both batteries' locations
4. Identify the positive (+) and negative (-) terminals on both the loader's battery and the assisting vehicle's battery.
5. Connect one end of the red (positive) jumper cable to the positive (+) terminal of the assisting vehicle's battery.
6. Connect the other end of the red (positive) cable to the positive (+) terminal of the skid steer loader's battery.
7. Connect one end of the black (negative) jumper cable to the negative (-) terminal of the assisting vehicle's battery.



DANGER! Do not connect the other end of the black (negative) cable directly to the skid steer loader's battery. Instead, attach it to a clean, unpainted metal surface on the loader's chassis, away from the battery. This will ground the battery and prevent sparks near the battery.

8. Start the engine of the assisting vehicle and let it run for a few minutes, allowing the assisting vehicle's alternator to charge the dead battery in the skid steer loader.
9. After a few minutes, start the skid steer loader. If it starts successfully, let it run for a while to charge its battery further.
10. In the reverse order of connection, remove the jumper cables:
 - a) Remove the black (negative) cable from the skid steer loader's chassis.
 - b) Remove the black (negative) cable from the assisting vehicle's battery.
 - c) Remove the red (positive) cable from the skid steer loader's battery.
 - d) Remove the red (positive) cable from the assisting vehicle's battery.
11. Allow the skid steer loader to run for a while to ensure its battery is sufficiently charged.
12. Turn off the engines of both the skid steer loader and the assisting vehicle.
13. Double-check that all connections have been disconnected properly. Secure any loose cables and ensure they are stowed safely.

Contact Us

Thank you for choosing our products! If you have any questions or comments, contact us at help@cs-supportpro.com and we'll resolve your issue ASAP!

For a .pdf copy of the latest version of these instructions, use the appropriate app on your smartphone to scan the QR code to the right.

